

MUELLER® LINESEAL III® , LINESEAL XP™ , **Mueller Co.** LINESEAL XP II™ BUTTERFLY VALVES 3"-20" DESIGN*

11.1

Rev. 9-09

MUELLER LINESEAL III (Class 150B), LINESEAL XP*, LINESEAL XP II (Class 250B) Butterfly Valve Features

- ❑ **CHEVRON V-TYPE PACKING--**
is self-adjusting, long lasting and should never need replacement because quarter-turn valve operation causes little or no wear. Packing bears on turned, ground and polished stainless steel.
- ❑ **CORROSION RESISTANT SHAFT--**
is constructed of stainless steel. Shaft is one-piece, through-shaft construction sized to meet or exceed requirements of AWWA Standard C504 for Class 150B or Class 250B service.
- ❑ **HEAVY DUTY BODY--**
is extra heavy with flanges fully faced and drilled per ANSI B16.1 Class 125 standard**. Other ends available include integrally cast mechanical joint and slip-on (for DI and PVC C900). Operator mounting trunnion is machined and drilled for four-bolt connection.
- ❑ **SELF-LUBRICATING BEARINGS--**
are liberally sized, chemically inert bearings that are self-lubricating and should outlast the life of the pipeline.
- ❑ **STREAMLINED DISC--**
has lens-shaped design to minimize pressure drop and turbulence. Full open valve creates no more friction loss than a 45° elbow. Disc is secured to the shaft by stainless steel pins sized to transmit torques required and withstand stresses imposed under severe operating conditions. Disc has stainless steel disc edge.
- ❑ **ELASTOMERIC BODY SEAT--**
is made of a special rubber compound (Buna N) that is bonded to the body by a patented process. The seat cannot be torn from the body under normal pipeline conditions. The precision molding process also ensures that the disc-seat indentation cannot cause excessive wear or abrasion upon closing.
- ❑ **TAMPER-PROOF DISC CENTERING--**
provided by precision molded flats in the bonded seat at the body trunnion mate with machined flats on the disc to provide tamperproof centering of the disc in the body. Positive disc alignment, without play, assures long seat life.

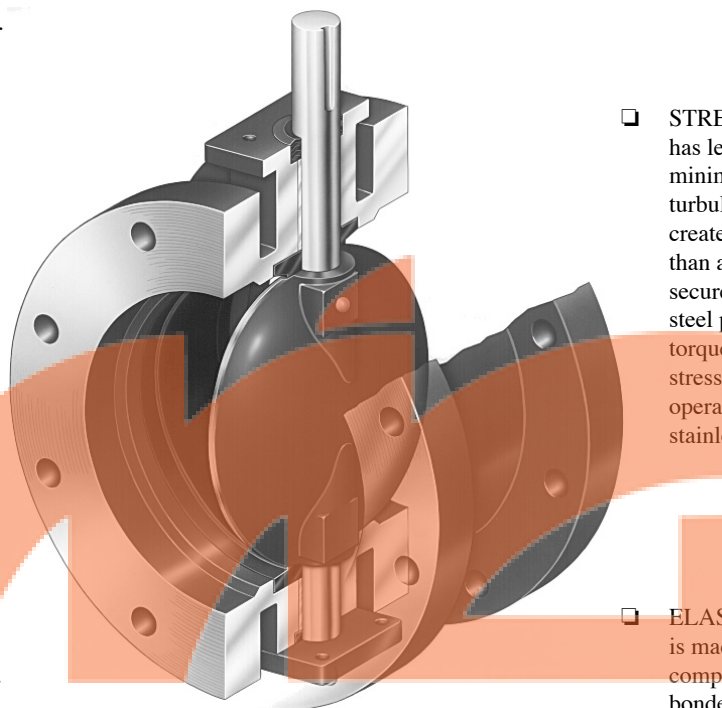

*Lineseal XP Valves 3" and 4" only.

**Lineseal XP Valve flanges drilled to ANSI B16.1 Class 250 standard.

11.2

Mueller Co.**MUELLER® LINESEAL III® , LINESEAL XP™ ,
LINESEAL XP II™ BUTTERFLY VALVES 24"-48"* DESIGN**

Rev. 9-09

**MUELLER LINESEAL III (Class 150B), LINESEAL XP, LINESEAL XP II (Class 250B)
Butterfly Valve Features**

- ❑ **CORROSION RESISTANT SHAFT--**
is constructed of stainless steel. Two-piece, stub-type shafts are sized per AWWA Standard C504, Class 150B or Class 250.
- ❑ **CHEVRON V-TYPE PACKING--**
is self-adjusting packing in top trunnion of valve body where shaft protrudes.
- ❑ **STRONG DISC AND SHAFT CONNECTIONS--**
with generously sized stainless steel pins designed to transmit torques required and withstand stresses imposed under severe operating conditions.
- ❑ **PRESET TWO-WAY THRUST BEARING ASSEMBLY--**
is preset at factory. On valves 30" and larger, assembly consists of stainless steel stud fastened to the bottom of the valve shaft. Stud extends beyond the bottom cover. Thrust collar is threaded to the stud and pinned. On 24" valves thrust collar is pinned to shaft and adjustment provided by bronze spacers. Thrust collar cavity is packed with grease and fully gasketed to prevent leakage.
- ❑ **HEAVY DUTY BODY--**
is extra heavy with flanges fully faced and drilled per ANSI B16.1 Class 250 or Mechanical Joint ends are also available.
- ❑ **SELF-LUBRICATING, SLEEVE-TYPE BEARINGS--**
are used in both trunnions of the valve body. PTFE lined with special non-metallic backing. Provide electrical insulation between disc and shaft to prevent galvanic corrosion. Lower coefficient of friction reduces operating torque requirements.
- ❑ **FLOW-THROUGH DISC*--**
provides less pressure drop in full-open position than conventional disc shapes. (On 24" size valves the arch side of disc is closed and the flat side is open, forming a slightly concave surface.) Disc structure has no internal cores that can shift during casting, no hollow chambers that can collect water, freeze and fracture the disc. Disc edge has stainless steel spherically shaped seating surface.
- ❑ **ELASTOMERIC SEAT--**
is made of a special rubber compound (Buna N) that seals a full 360 against a stainless steel spherical disc edge. Unique grooved-seal design, coupled with the wide spherically shaped seating edge of the disc, allows greater disc closure tolerance (up to 1° off center in closed position without leakage). Seat is mechanically retained in body without metal hardware by a cast epoxy compound that ensures the seat conforms to the exact radius of the disc with uniform contact pressure. It is fully field adjustable and replaceable.

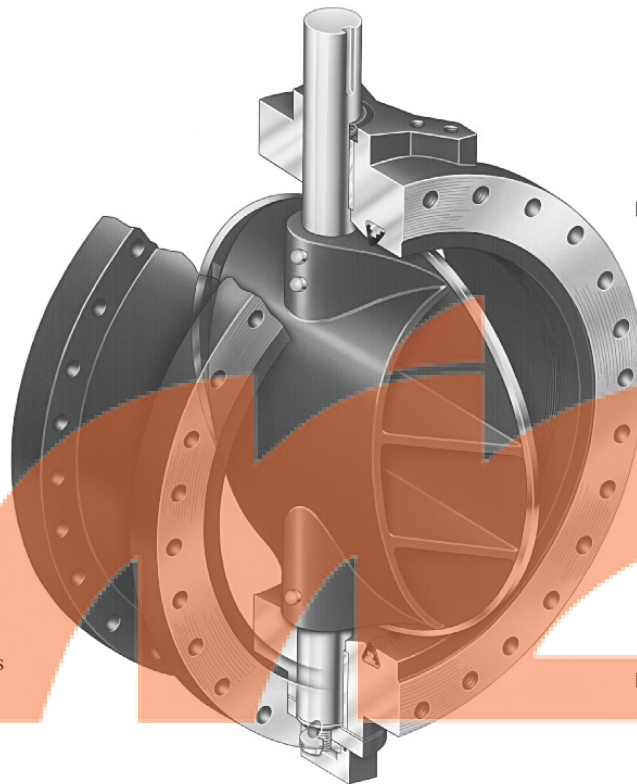

* Contact your Mueller representative for valves sizes larger than 48" and for Linesal XP Valves with Class 250 flanges, this page applies to 24"-48" sizes.

MUELLER® LINESEAL III® BUTTERFLY VALVES (Class 150B) 3" - 48"*



11.3

Rev. 9-09

- Catalog number--
 - 3211-6** Flanged Ends Class 125
Sizes--3", 4", 6", 8", 10", 12", 14", 16", 18", 20", 24", 30", 36", 42", 48"
 - 3211-20** Mechanical joint ends (with mechanical joint unassembled accessories)
Sizes--4", 6", 8", 10", 12", 14", 16", 18", 20", 24", 30", 36", 42", 48"
 - 3211-23** Mechanical joint ends (without mechanical joint accessories)
Sizes--4", 6", 8", 10", 12", 14", 16", 18", 20", 24", 30", 36", 42", 48"
 - 3211-16** Flanged Class 125 by mechanical joint ends (with mechanical joint unassembled accessories)
Sizes--6", 8", 10", 12", 14", 16", 18", 20", 24", 30", 36
 - 3211-19** Flanged Class 125 by mechanical joint ends (without mechanical joint unassembled accessories)
Sizes--6", 8", 10", 12", 14", 16", 18", 20", 24", 30", 36
 - 3211-41** Flanged Class 125 by slip-on
Sizes--12", 16"
 - 3211-38** Slip-on by slip-on
Sizes--12", 16"
- Meets or exceeds all applicable requirements of ANSI/AWWA C504 Standard Class 150B; NSF 61 certified
- Buried service valves: I.D. and O.D. coated
- Body - Cast Iron ASTM A-126
- Flanges drilled per ANSI B16.1 Class 125
- Above ground valves (ordered with either a handwheel, position indicator on the actuator, or lever): minimum 4 mills epoxy coated interior and exterior; meets AWWA C504 standard.
- Seat-in-body design reduces seat failure due to **corrosive** buildup in the valve and pipeline
- Through-disc pinning provides a tight disc-to-shaft pin connection, greatly reducing the possibility of loosening through vibration
- Disc edge is 316 Stainless Steel
- Disc - Cast Iron ASTM A-126 (3", 4", 6" Stainless Steel ASTM A-743 CF8M)
- Symmetrical disc for higher Cv and lower head loss
- Nonmetallic bearings prevent galvanic corrosion and provides lower coefficient of friction
- Chevron "V" type packing is self-adjusting to last the life of the valve
- 3"-24" Standard 304 SS hardware.

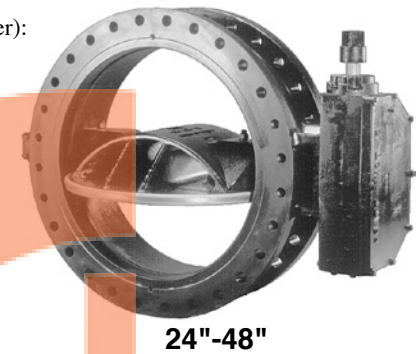

Options

- MDT Actuator with handwheel or chainwheel and position indicator
- MDT Actuator with cylinder actuator (also available with manual override, handjack and 4-way solenoid valve)
- Hand lever for 3"-10" valves
- 200 psi test
- EPDM Rubber seat and seals
- 316 Stainless steel fasteners
- Additional 4 mills minimum Epoxy interior and/or exterior
- Holiday testing
- Ground level position indicator

Standard Buried Service Actuators

Note: Actuator size subject to change based on actual pipeline conditions.

Valve size	Actuator	Number of turns
3"-12"	MDT-2S	32
14"-16"	MDT-3S	30
18"-24"	MDT-4S	40
30"-36"	MDT-5	44
42"	MDT-5S	136
48"	MDT-6S	215

Slotted-Lever (3"-12")

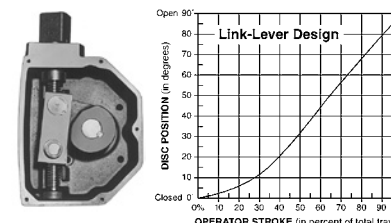
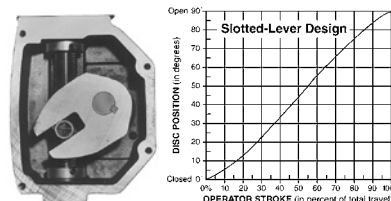

*Contact your Mueller representative for valve sizes larger than 48"

11.4



MUELLER® LINESEAL III® BUTTERFLY VALVES-(CLASS 150B) 3"-48"*-FLANGED ENDS

Rev. 9-09

Dimensions - for Line Seal III Valves Flanged (Class 125) Ends, 3"-20" Sizes.

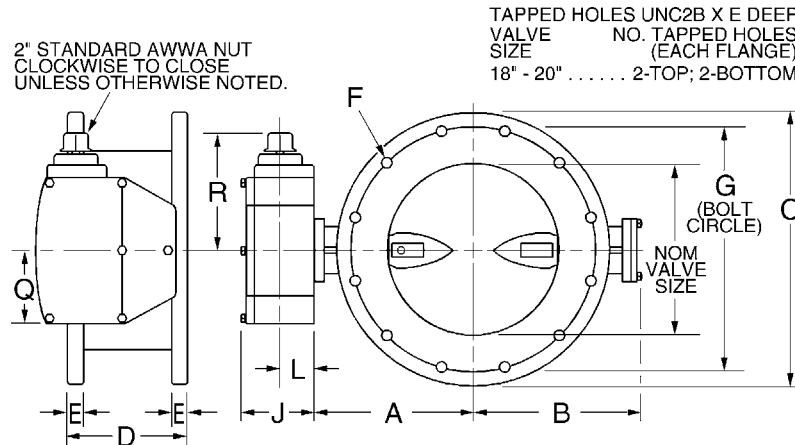

Dimensions - for Line Seal III Valves Flanged (Class 125) Ends, 24"-48" Sizes.

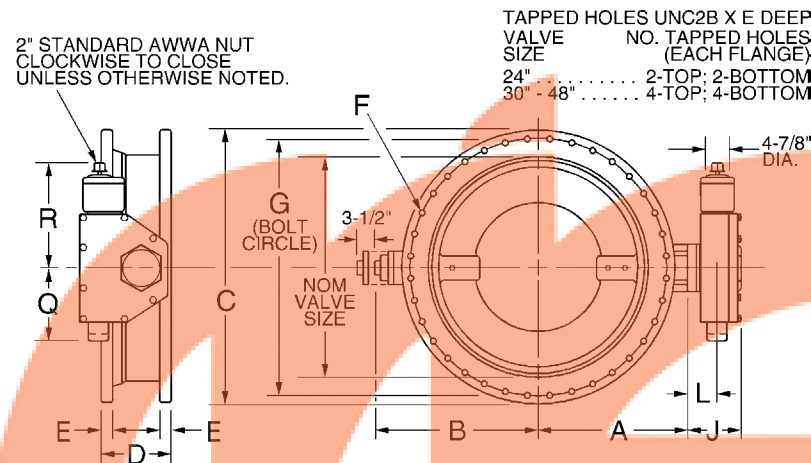

Notes: These dimensions are correct at time of publication but are not to be construed as certified drawings. Certified drawings available upon request.

Actuator size subject to change based on actual pipeline conditions.

Dimension+	Nominal size*														
	3"	4"	6"	8"	10"	12"	14"	16"	18"	20"	24"	30"	36"	42"	48"
A	4.75	5.50	6.50	7.75	9.00	10.5	11.88	13.50	14.38	16.00	18.63	21.50	25.44	29.88	34.06
B	3.88	4.13	5.13	6.50	9.88	11.38	12.63	14.50	15.38	17.00	18.63	24.38	28.25	32.88	37.13
C	7.50	9.00	11.00	13.50	16.00	19.00	21.00	23.50	25.00	27.50	32.00	38.75	46.00	53.00	59.50
D†	5.00	5.00	5.00	6.00	8.00	8.00	8.00	8.00	8.00	8.00	8.00	12.00	12.00	12.00	15.00
E	.75	.94	1.00	1.13	1.19	1.25	1.38	1.44	1.56	1.69	1.88	2.13	2.38	2.63	2.75
F (number and size of holes)	4--.63	8--.63	8--.75	8--.75	12--.88	12--.88	12--1	16--1	16--1.13	20--1.13	20--1.25	28--1.25	32--1.50	36--1.50	44--1.50
G	6.00	7.50	9.50	11.75	14.25	17.00	18.75	21.25	22.75	25.00	29.50	36.00	42.75	49.50	56.00
J	4.69	4.69	4.69	4.69	4.69	4.69	5.63	5.63	6.38	6.38	6.38	7.56	7.56	8.31	9.88
L	2.00	2.00	2.00	2.00	2.00	2.00	2.44	2.44	2.84	2.84	2.84	3.47	3.47	3.94	5.06
Q	4.50	4.50	4.50	4.50	4.50	4.50	5.38	5.38	6.75	6.75	6.75	10.00	10.00	15.94	14.19
R	8.25	8.25	8.25	8.25	8.25	8.25	10.38	10.38	11.31	11.31	11.31	17.00	17.00	19.88	26.50
Turns to open	32	32	32	32	32	32	30	30	40	40	40	44	44	136	215
Actuator (see notes)	MDT-2S	MDT-2S	MDT-2S	MDT-2S	MDT-2S	MDT-2S	MDT-3S	MDT-3S	MDT-4S	MDT-4S	MDT-4S	MDT-5	MDT-5	MDT-5S	MDT-6S

* Larger sizes available upon request.

+ All dimensions are in inches.

† $\pm 1/16"$ for 10" valves, and $\pm 1/8"$ for 12"-48" valves per Flange Standard ANSI B16.1.

MUELLER® LINESEAL III® BUTTERFLY VALVES CLASS 150B 6"-20" - M.J. X FL.



11.5

Rev. 9-09

Dimensions - for Line Seal III Valves Mechanical Joint by Flange (Class 125) Ends, 6"-20" Sizes.

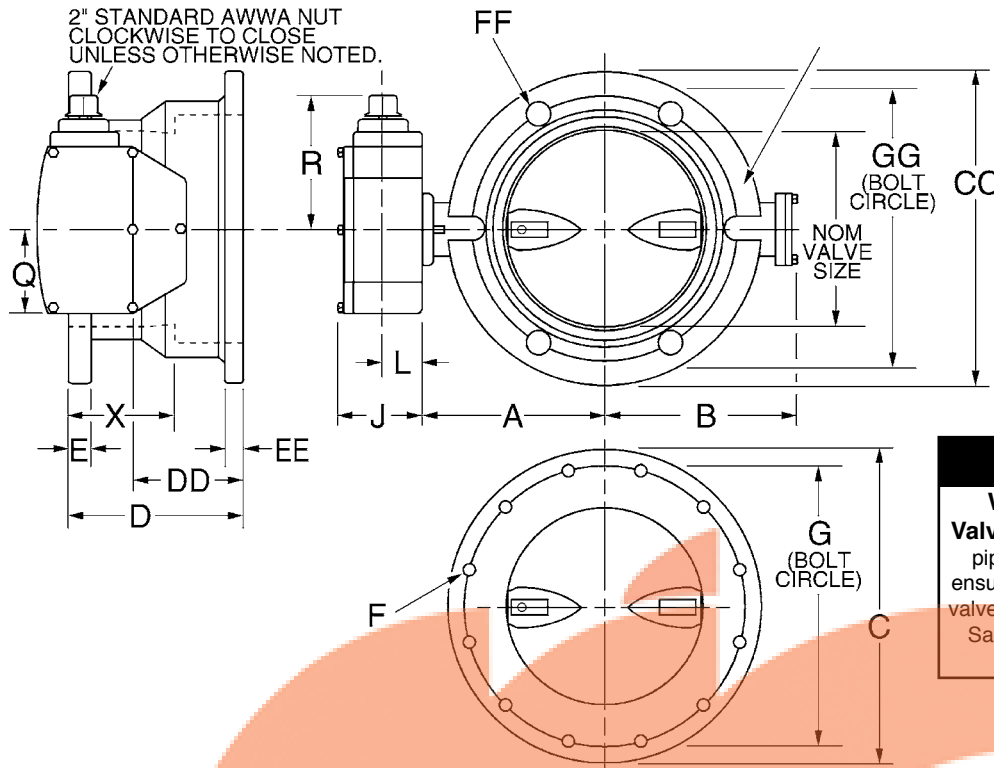

CAUTION
When using 10" and 12" Valves on Class 200 PVC Pipe, pipe end I.D. must be bevelled to ensure clearance for disc and proper valve operation. Contact your Mueller Sales Representative for detailed instructions.

Notes: These dimensions are correct at time of publication but are not to be construed as certified drawings. Certified drawings available upon request.
Actuator size subject to change based on actual pipeline conditions.

Dimension+	Nominal size							
	6"	8"	10"	12"	14"	16"	18"	20"
A	6.50	7.75	9.00	10.50	11.88	13.50	14.38	16
B	5.13	6.50	9.88	11.38	12.75	14.38	15.25	16.88
C	11.00	13.50	16.00	19.00	21.00	23.50	25.00	27.50
CC	11.00	13.25	15.56	17.94	20.31	22.56	24.69	27.09
D†	6.75	7.31	8.62	8.63	9.75	10.00	10.13	10.25
DD	4.25	4.31	4.62	4.63	5.75	6.00	6.13	6.25
E	1.06	1.13	1.25	1.25	1.38	1.44	1.56	1.69
EE	1.06	1.13	1.19	1.25	1.31	1.38	1.44	1.50
F (number and size of holes)	8--.75	8--.75	12--.88	12--.88	12--1.00	16--1.00	16--1.13	20--1.13
FF (number and size of holes)	6--.75	6--.75	8--.75	8--.75	10--.75	12--.75	12--.75	14.75
G	9.50	11.75	14.25	17.00	18.75	21.25	22.75	25.00
GG	9.50	11.75	14.00	16.25	18.75	21.00	23.25	25.50
J	4.69	4.69	4.69	4.69	5.63	5.63	6.38	6.38
L	2.00	2.00	2.00	2.00	2.44	2.44	2.84	2.84
Q	4.50	4.50	4.50	4.50	5.38	5.38	6.75	6.75
R	8.75	8.25	8.25	8.25	10.38	10.38	11.31	11.31
X	4.25	4.81	6.13	6.13	6.25	6.50	6.63	6.75
Turns to open	32	32	32	32	30	30	40	40
Actuator (see notes)	MDT-2S	MDT-2S	MDT-2S	MDT-2S	MDT-3S	MDT-3S	MDT-4S	MDT-4S

+ All dimensions are in inches.

11.6



MUELLER® LINESEAL III® BUTTERFLY VALVES CLASS 150B 4"-48" - M.J. ENDS

Rev. 9-09

Dimensions - for Line seal III Valves M.J. Ends, 4"-20" Sizes.

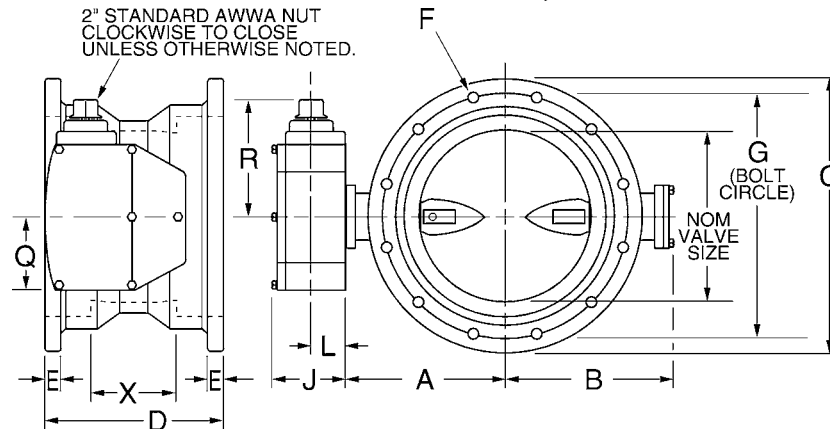

Dimensions - for Mueller Line seal III Butterfly Valves M.J. Ends, 24"-48" Sizes.

CAUTION

When using 10" and 12" Valves on Class 200 PVC Pipe, pipe end I.D. must be beveled to ensure clearance for disc and proper valve operation. Contact your Mueller Sales Representative for detailed instructions.

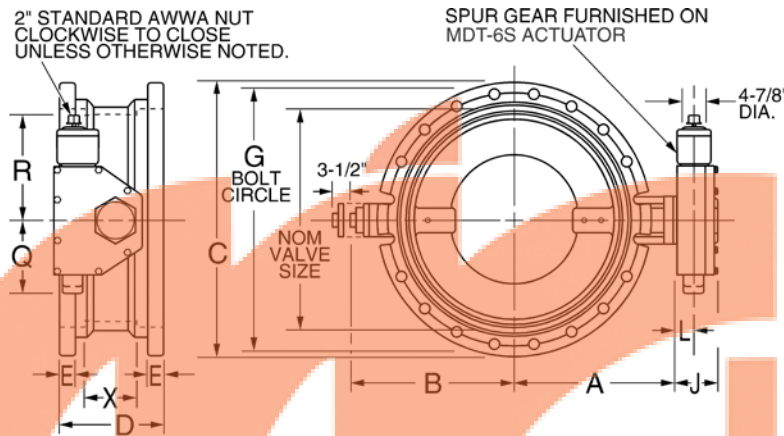

Notes: These dimensions are correct at time of publication but are not to be construed as certified drawings. Certified drawings available upon request.
 Actuator size subject to change based on actual pipeline conditions.

Dimension+	Nominal size													
	4"	6"	8"	10"	12"	14"	16"	18"	20"	24"	30"	36"	42"	48"
A	5.50	6.50	7.75	9.00	10.50	11.88	13.50	14.38	16.00	18.63	21.50	25.44	29.88	34.06
B	4.13	5.13	6.50	9.75	11.38	12.75	14.50	15.38	17.00	18.38	24.13	28.00	32.75	36.88
C	9.00	11.00	13.25	15.56	17.94	20.31	22.56	24.69	27.09	31.56	39.00	45.88	53.00	59.88
D	8.13	8.50	8.63	9.25	9.25	11.50	12.00	12.25	12.50	13.25	18.00	22.00	22.00	24.00
E	1.00	1.06	1.13	1.19	1.25	1.31	1.38	1.38	1.50	1.63	1.81	2.00	2.00	2.00
F (number and size of holes)	4--.75	6--.75	6--.75	8--.75	8--.75	10--.75	12--.75	12--.75	14--.75	16--.75	20--1.00	24--1.00	28--1.25	32--1.25
G	7.50	9.50	11.75	14.00	16.25	18.75	21.00	23.25	25.25	30.00	36.88	43.75	50.63	57.50
J	4.69	4.69	4.69	4.69	4.69	5.63	5.63	6.38	6.38	6.38	7.56	7.56	8.31	10.19
L	2.00	2.00	2.00	2.00	2.00	2.44	2.44	2.84	2.84	2.44	3.47	3.47	3.94	5.06
Q	4.50	4.50	4.50	4.50	4.50	5.38	5.38	6.75	6.75	6.75	10.00	10.00	15.94	14.19
R	8.25	8.25	8.25	8.25	8.25	10.38	10.38	11.31	11.31	11.31	17.00	17.00	19.88	26.50
X	3.12	3.50	3.63	4.25	4.25	4.50	5.00	5.25	5.50	6.38	10.00	14.00	14.00	16.00
Turns to open	32	32	32	32	32	30	30	40	40	40	44	44	136	215
Actuator (see notes)	MDT-2S	MDT-2S	MDT-2S	MDT-2S	MDT-2S	MDT-3S	MDT-3S	MDT-4S	MDT-4S	MDT-4S	MDT-5	MDT-5	MDT-5S	MDT-6S

+ All dimensions are in inches.

MUELLER® LINESEAL III® BUTTERFLY VALVES CLASS 150B 12", 16" - SL. X FL.



11.7

Rev. 9-09

Dimensions - for Line Seal III Valves Slip-on by Flanged Ends (Class 125), 12", 16" Sizes.

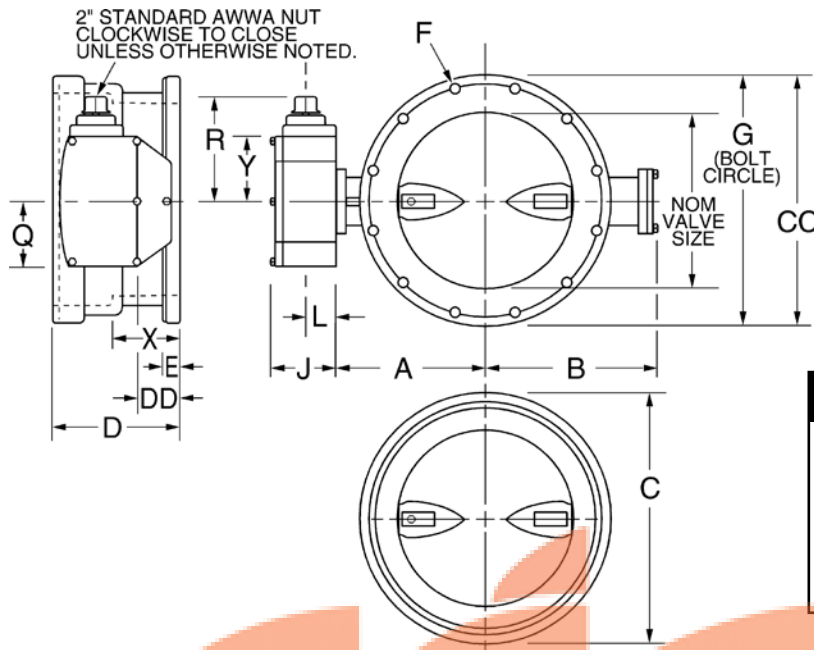

CAUTION
When using 12" Valves on Class 200 PVC Pipe, pipe end I.D. must be bevelled to ensure clearance for disc and proper valve operation. Contact your Mueller Sales Representative for detailed instructions.

Notes: These dimensions are correct at time of publication but are not to be construed as certified drawings. Certified drawings available upon request.
Actuator size subject to change based on actual pipeline conditions.

	Pipe size	
	12"	16"
Pipe O.D.	13.20	17.40

Dimension+	Nominal size	
	12"	16"
A	10.50	13.50
B	11.38	13.88
C (Slip on end)	16.38	21.25
CC (Flanged end)	19.00	23.50
D	11.50	11.50
DD	4.00	4.00
E	1.25	1.44
F (number and size of holes)	12--.88	16--1.00
G	17.00	21.25
J	4.69	5.63
L	2.00	2.44
Q	4.50	5.38
R	8.25	10.38
X (Laying length)	6.56	9.19
Turns to open	32	30
Actuator (see notes)	MDT-2S	MDT-3S

+ All dimensions are in inches.

- IMPORTANT:**
1. Slip On end of this valve NOT FOR USE with IPS O.D. Pipe.
 2. Slip On end of this valve for use with Tyton™ Rubber Ring Gasket (Tyton is a registered Trade Mark of U.S. Pipe & Foundry Co.).

11.8



MUELLER® LINESEAL III® BUTTERFLY VALVES CLASS 150B 12", 16" - SLIP-ON

Rev. 9-09

Dimensions - for Mueller Line Seal III Butterfly Valves Slip-on Ends, 12", 16" Sizes.

2" STANDARD AWWA NUT
CLOCKWISE TO CLOSE
UNLESS OTHERWISE NOTED.

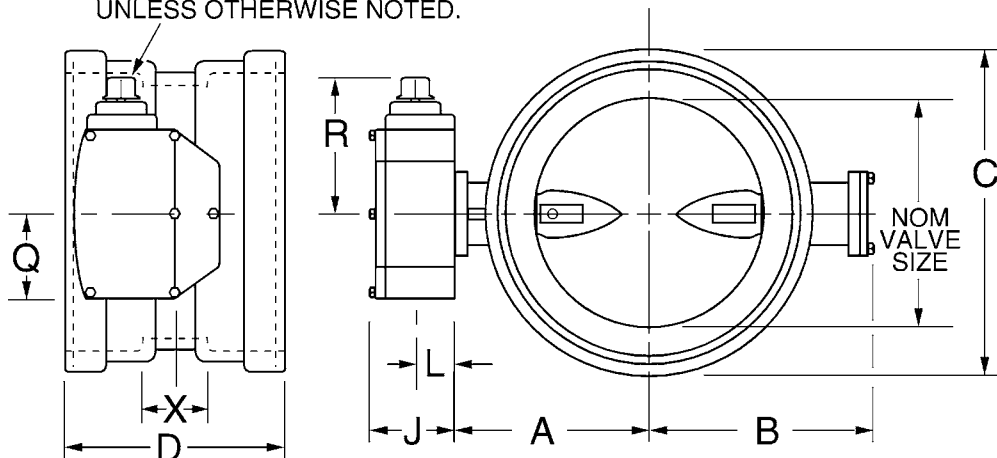

CAUTION

When using 12" Valves on Class 200 PVC Pipe, pipe end I.D. must be bevelled to ensure clearance for disc and proper valve operation. Contact your Mueller Sales Representative for detailed instructions.

Notes: These dimensions are correct at time of publication but are not to be construed as certified drawings. Certified drawings available upon request.
Actuator size subject to change based on actual pipeline conditions.

	Pipe size	
	12"	16"
Pipe O.D.	13.20	17.40

Dimension+	Nominal size	
	12"	16"
A	10.50	13.50
B	11.38	14.50
C	16.38	21.25
D	15.00	15.00
J	4.69	5.63
L	2.00	2.44
Q	4.50	5.38
R	8.25	10.38
X (Laying length)	5.13	4.75
Turns to open	32	30
Actuator (see notes)	MDT-2S	MDT-3S

+All dimensions are in inches.

IMPORTANT: 1. This valve NOT FOR USE with IPS O.D. Pipe.
2. This valve for use Tyton™ Rubber Ring Gasket (Tyton is a registered Trade Mark of U.S. Pipe & Foundry Co.).

MUELLER® LINESEAL III® BUTTERFLY VALVES CLASS 150B 3"-48"* PARTS



11.9

Rev. 9-09

Line Seal III Butterfly Valve Replacement Parts

Catalog Part No.	Description	Material
BF100	Body	Cast iron ASTM A126 CL.B
BF101	Disc**	Cast iron ASTM A126, Class B with 316 Edge
BF102	Shaft	Stainless Steel 18-8 Type 304 ASTM A-276
BF103	Squeeze pin	Stainless Steel 18-8 Type 304 ASTM A-276
BF104	Bearing	Nylatron GS
BF105	Packing	Chevron V-Type
BF106	Key	Carbon Steel C-1045
BF107	Cover	Cast Iron ASTM A-48 Class 40
BF108	Lockwasher	Stainless Steel Type 304
BF109	Cap Screw	Stainless Steel Type 304
BF110	Seat	Buna N
BF111	Plug	Stainless Steel Type 304
BF112	Bearings	PTFE Lined, Filament Wound, Reinforced Plastic, Fiberglass Backed
BF113	Disc	Ductile Iron ASTM A-536 Grade 65-45-12
BF114	Disc edge	Stainless Steel Type 316 ASTM A-240
BF115	Top stub shaft	Stainless Steel Type 304 ASTM A-276 (Standard) Stainless Steel Type 316 ASTM A-276
BF116	Bottom stub shaft	Stainless Steel Type 304 ASTM A-276 (Standard) Stainless Steel Type 316 ASTM A-276
BF117	Packing	Buna N
BF118	Bottom cover	Cast Iron ASTM A-48 Class 40
BF119	Cap screws	Carbon Steel
BF120	Squeeze pins	Stainless Steel Type 304 ASTM A-479
BF121	Thrust collar	Stainless Steel Type 420
BF122	Thrust collar shims	Bronze
BF123	Spring pin	Stainless Steel Type 420
BF124	O-ring	Buna N
BF125	Packing retainer	Nylon
BF126	Bearings	Duralon
BF127	Disc	Ductile Iron ASTM A-536 Grade 65-45-12
BF128	Top stub shaft	Stainless Steel Type 304 ASTM A-276
BF129	Bottom stub shaft	Stainless Steel Type 304 ASTM A-276
BF130	Bottom cover	Cast Iron ASTM A-126 Class B
BF131	Bottom cover cap	Cast Iron ASTM A-126 Class B
BF132	Taper pins	Stainless Steel Type 630 ASTM A-564 Cond. H-1150
BF133	Lockwashers	Stainless Steel Type 304
BF134	Hex nuts	Stainless Steel Type 304
BF135	O-rings	Buna N
BF136	Thrust bearing stud	Stainless Steel Type 304
BF137	Thrust collar	Bronze ASTM B-505 Alloy C93200
BF138	Dowel pin	Alloy Steel
BF139	Bottom cover gasket	Blended Fiber, Cured Nitril Binder
BF140	O-ring	Buna N

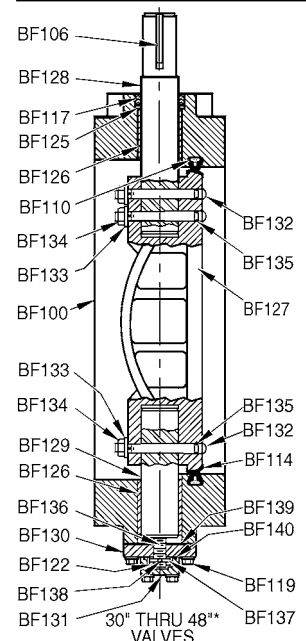
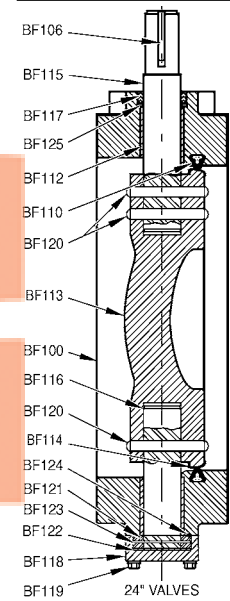
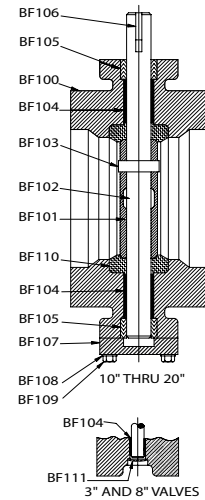

* Contact your Mueller representative for sizes larger than 48"
** 3", 4", 6" is ASTM A-351 CF8M Stainless Steel.

Rev. 9-09

- Catalog number--
5227-6 Flanged (Class 250) Ends; **ANSI 250lb Drilling B16.1**
Sizes--3", 4", 6", 8", 10", 12", 14", 16", 18", 20", 24", 30", 36", 42", 48"*
- 250psig (1723kPa) maximum working pressure
- Meets or exceeds all applicable requirements of ANSI/AWWA C504 Standard Class 250B; NSF 61 certified
- Body - Ductile Iron ASTM A-536 (65-45-12)
- Buried service valves: I.D. and O.D. coated
- Above ground valves (ordered with either a handwheel, position indicator on the actuator, or lever); minimum 4 mills epoxy coated interior and exterior; meets AWWA C-504 standards.
- Seat-in-body design reduces seat failure due to corrosive buildup in the valve and pipeline
- Disc edge is 316 Stainless Steel
- Disc - Ductile Iron ASTM A-536 (65-45-12) (3"-4" Stainless Steel ASTM A-531 CF8M)
- Nonmetallic bearings prevent galvanic corrosion and provides lower coefficient of friction
- Chevron "V" type packing is self-adjusting to last the life of the valve
- 3"-24" Standard 304 SS hardward.



3"-20"

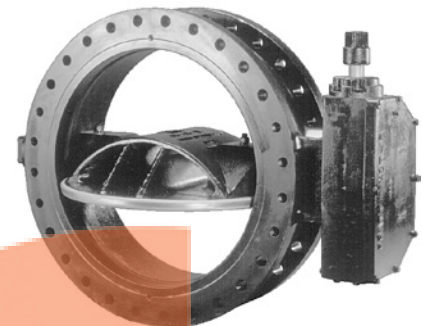

24"-48"

Options

- MDT Actuator with handwheel or chainwheel and position indicator
- MDT Actuator with cylinder actuator (also available with manual override, handjack and 4-way solenoid valve)
- EPDM rubber seat and seals
- 304/316 Stainless Steel Fasteners
- Additional 4 mils minimum Epoxy interior and/or exterior
- Holiday testing
- Ground level position indicator

Standard Buried Service Actuators

Note: Actuator size subject to change based on actual pipeline conditions.

Valve size	Actuator	Number of turns
3"-8"	MDT-2S	32
10"-14"	MDT-3S	30
16"-18"	MDT-4S	40
20"-24"	MDT-5	44
30"-36"	MDT-5S	136
42"-48"	MDT-6S	215

Slotted-Lever (3"-8")

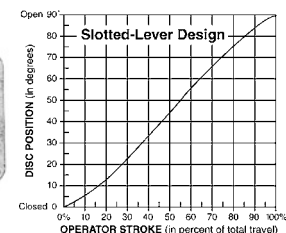

Link-Lever (10"-48")

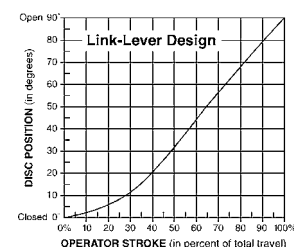

MUELLER® LINESEAL XP™ BUTTERFLY VALVES (CLASS 250B) 3"-48"* - FLANGE ENDS



Shaded area indicates change Rev. 10-11

Dimensions - for Line seal XP Valves - Flange (ANSI B16.1 Class 250) Ends, 3"-48"* Sizes.

TAPPED HOLES	UNC2B X E DEEP
VALVE	NO. TAPPED HOLES
SIZE	(EACH FLANGE)
18" - 20".....	4(2 OVER BOTH SHAFT AREAS)
30" - 48".....	8(4 OVER BOTH SHAFT AREAS)

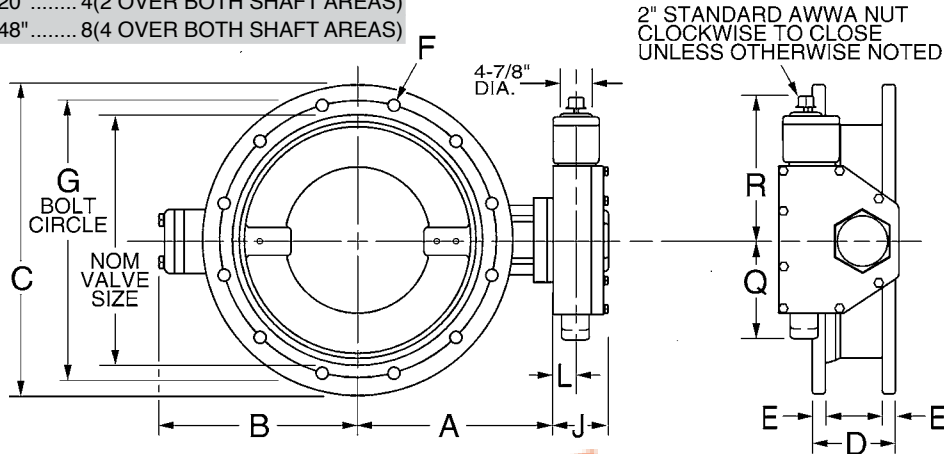

NOTES: These dimensions are correct at time of publication but are not to be construed as certified drawings. Certified drawings are available upon request.

Actuator size subject to change based on actual pipeline conditions.

Dimension+	Nominal size														
	3"	4"	6"	8"	10"	12"	14"	16"	18"	20"	24"	30"	36"	42"	48"
A	4.75	5.50	7.25	8.50	9.75	11.50	12.75	14.00	15.25	17.00	19.75	25.63	28.13	32.13	36.25
B	3.25	3.50	8.38	9.63	11.00	12.63	13.88	15.13	16.38	17.63	20.25	26.00	31.13	35.13	39.63
C	8.25	10.00	12.50	15.00	17.50	20.50	23.00	25.50	28.00	30.50	36.00	43.00	50.00	57.00	65.00
D	5.00	5.00	6.00	8.00	8.00	8.00	12.00	12.00	12.00	12.00	12.00	12.00	15.00	15.00	15.00
E	1.13	1.25	1.44	1.63	1.88	2.00	2.13	2.25	2.38	2.50	2.75	3.00	3.38	3.69	4.00
F (number and size of holes)**	8--.88	8--.88	12--.88	12--1.00	16--1.12	16--1.25	20--1.25	20--1.38	20--1.38	20--1.38	24--1.62	20--2.00	24--2.25	28--2.25	32--2.25
	--	--	--	--	--	--	--	--	4--1.25	4--1.25	--	8--1.50	8--2.00	8--2.00	8--2.00
G	6.63	7.88	10.63	13.00	15.25	17.75	20.25	22.50	24.75	27.00	32.00	39.25	46.00	52.75	60.75
J	4.69	4.69	4.69	4.69	5.63	5.63	5.63	6.38	6.38	7.56	7.56	7.56	8.31	11.13	
L	2.00	2.00	2.00	2.00	2.44	2.44	2.44	2.84	2.84	3.49	3.49	3.49	3.94	5.06	
Q	4.50	4.50	4.50	4.50	5.38	5.38	5.38	6.75	6.75	10.00	10.00	10.00	15.94	14.19	
R	8.25	8.25	8.25	8.25	10.38	10.38	10.38	11.31	11.31	17.00	17.00	17.00	19.88	26.50	
Turns to Open	32	32	32	32	30	30	30	40	40	44	44	44	136	215	
Actuator (see notes)	MDT-2S	MDT-2S	MDT-2S	MDT-2S	MDT-3S	MDT-3S	MDT-3S	MDT-4S	MDT-4S	MDT-5	MDT-5	MDT-5	MDT-5S	MDT-6S	

CONTACT FACTORY

+All dimensions are in inches.

*Consult your Mueller representative for sizes larger than 48".

**Top row: number and size of clearance holes for bolts; bottom row: number and size of threaded holes for studs.

Rev. 9-09

- Catalog number--
 - 5227-6** Flanged (Class 250) Ends*; **ANSI B16.1 Class 125**
 Sizes--3", 4", 6", 8", 10", 12", 14", 16", 18", 20", 24", 30", 36", 42", 48"*
 - 5227-20** Mechanical joint ends
 (with mechanical joint unassembled accessories)
 Sizes--4", 6", 8", 10", 12", 14", 16", 18", 20", 24", 30", 36", 42", 48"*
 - 5227-23** Mechanical joint ends
 (without mechanical joint accessories)
 Sizes--4", 6", 8", 10", 12", 14", 16", 18", 20", 24", 30", 36", 42", 48"*
 - 5227-16** Flanged x Mechanical joint ends (with mechanical joint accessories)
 Sizes--6", 8", 10", 12", 14", 16", 18", 20", 24", 30", 36"
 - 5227-19** Flanged x Mechanical joint ends (without mechanical joint accessories)
 Sizes--6", 8", 10", 12", 14", 16", 18", 20", 24", 30", 36"
- 250psig (1723kPa) maximum working pressure
- Meets or exceeds all applicable requirements of ANSI/AWWA C504 Standard Class 250B; NSF 61 certified
- Body - Ductile Iron ASTM A-536 (65-45-12)
- Buried service valves: I.D. and O.D. coated
- Above ground valves (ordered with either a handwheel, position indicator on the actuator, or lever); minimum 4 mills epoxy coated interior and exterior.
- Seat-in-body design reduces seat failure due to corrosive buildup in the valve and pipeline (24"-48")
- Disc edge is 316 Stainless Steel
- Disc - Ductile Iron ASTM A-536 (65-45-12) (3", 4", 6" Stainless Steel ASTM A-531 CF8M)
- Through-disc pinning provides a tight disc-to-shaft pin connection, greatly reducing the possibility of loosening through vibration
- Symmetrical disc for higher Cv and lower head loss (3"-20")
- Nonmetallic bearings prevent galvanic corrosion and provides lower coefficient of friction
- Chevron "V" type packing is self-adjusting to last the life of the valve



3"-20"

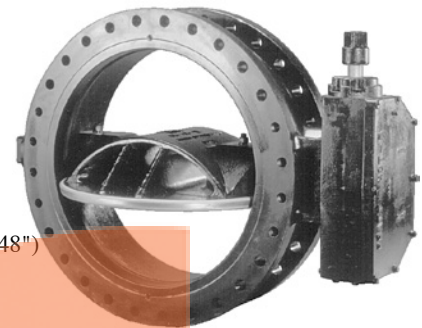

24"-48"

Options

- MDT Actuator with handwheel or chainwheel and position indicator
- MDT Actuator with cylinder actuator (also available with manual override, handjack and 4-way solenoid valve)
- EPDM rubber seat and seals
- 304/316 Stainless Steel Fasteners
- Additional 4 mils minimum Epoxy interior and/or exterior
- Holiday testing
- Ground level position indicator

Standard Buried Service Actuators

Note: Actuator size subject to change based on actual pipeline conditions.

Valve size	Actuator	Number of turns
3"-8"	MDT-2S	32
10"-14"	MDT-3S	30
16"-18"	MDT-4S	40
20"-24"	MDT-5	44
30"-36"	MDT-5S	136
42"-48"	MDT-6S	215

Slotted-Lever (3"-8")

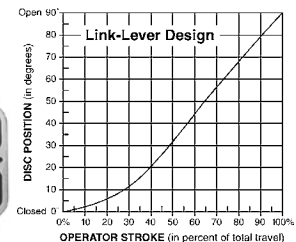
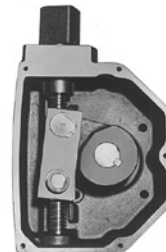
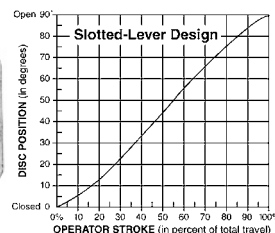

* Consult your Mueller representative for sizes larger than 48" or for valves with Class 125 flanges.

MUELLER® LINESEAL XPII™ BUTTERFLY VALVES (CLASS 250B) 3"-48" - FLANGE ENDS

Mueller Co. 11.13

Rev. 9-09

Dimensions - for Line seal XPII Valves - Flange (ANSI B16.1 Class 125) Ends, 3"-48"* Sizes.

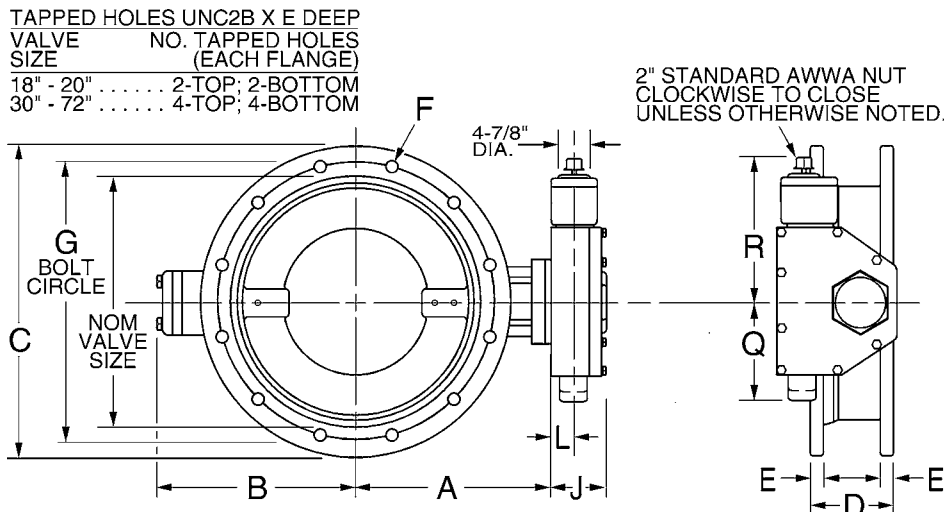

NOTES: These dimensions are correct at time of publication but are not to be construed as certified drawings. Certified drawings are available upon request.
 Actuator size subject to change based on actual pipeline conditions.

Dimension+	Nominal size														
	3"	4"	6"	8"	10"	12"	14"	16"	18"	20"	24"	30"	36"	42"	48"
A	4.75	5.50	6.50	7.75	9.00	10.50	11.88	13.50	14.38	16.00	18.63	21.50	25.44	29.88	34.06
B	3.25	3.50	5.13	6.50	9.88	11.38	12.75	14.38	15.25	16.88	18.38	24.13	28.00	32.69	36.88
C	7.50	9.00	11.00	13.50	16.00	19.00	21.00	23.50	25.00	27.50	32.00	38.75	46.00	53.00	59.50
D	5.00	5.00	5.00	6.00	8.00	8.00	8.00	8.00	8.00	8.00	8.00	12.00	12.00	12.00	15.00
E	.75	.94	1.00	1.13	1.19	1.25	1.38	1.44	1.56	1.69	1.88	2.13	2.38	2.63	2.75
F (number and size of holes)	4--.63	8--.63	8--.75	8--.75	12--.88	12--.88	12--1.00	16--1.00	16--1.13	20--1.13	20--1.25	28--1.25	32--1.50	36--1.50	44--1.50
G	6.00	7.50	9.50	11.75	14.25	17.00	18.75	21.25	22.75	25.00	29.50	36.00	42.75	49.50	56.00
J	4.69	4.69	4.69	4.69	5.63	5.63	5.63	6.38	6.38	7.56	7.56	8.31	8.31	9.88	9.88
L	2.00	2.00	2.00	2.00	2.44	2.44	2.44	2.84	2.84	3.47	3.47	3.47	3.47	5.06	5.06
Q	4.25	4.25	4.25	4.25	5.38	5.38	5.38	6.75	6.75	10.00	10.00	15.94	15.94	14.19	14.19
R	8.25	8.25	8.25	8.25	10.38	10.38	10.38	11.31	11.31	17.00	17.00	19.88	19.88	26.50	26.50
Turns to Open	32	32	32	32	30	30	30	40	40	44	44	44	136	215	215
Actuator (see notes)	MDT-2S	MDT-2S	MDT-2S	MDT-2S	MDT-3S	MDT-3S	MDT-3S	MDT-4S	MDT-4S	MDT-5	MDT-5	MDT-5	MDT-5S	MDT-6S	MDT-6S

+All dimensions are in inches.

11.14 **Mueller Co.**

MUELLER® LINESEAL XPII™ BUTTERFLY VALVES (CLASS 250B) 4"-48" - M.J. ENDS

Rev. 9-09

Dimensions - for Line Seal XPII Valves - Mechanical Joint Ends, 4"-48" Sizes.

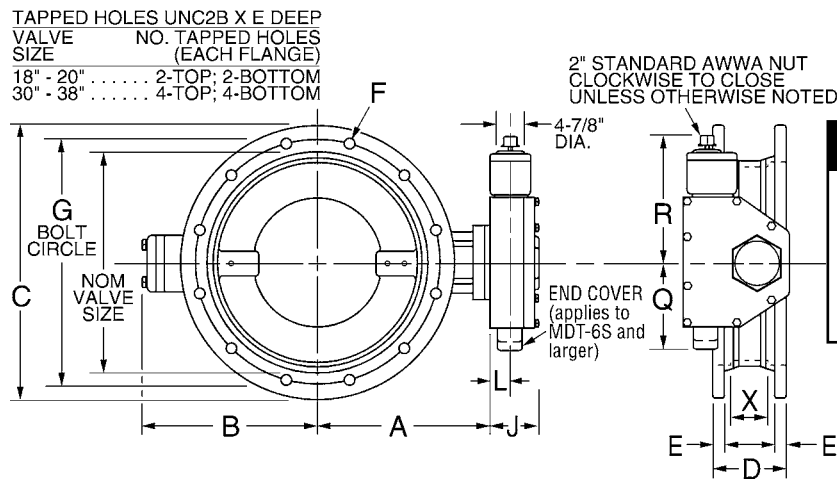

NOTES: These dimensions are correct at time of publication but are not to be construed as certified drawings. Certified drawings are available upon request.

Actuator size subject to change based on actual pipeline conditions.

Dimension+	Nomnal Size													
	4"	6"	8"	10"	12"	14"	16"	18"	20"	24"	30"	36"	42"	48"
A	5.50	6.50	7.75	9.00	10.50	11.88	13.50	14.38	16.00	18.63	21.50	25.44	29.88	34.06
B	3.50	5.13	6.50	9.88	11.38	12.75	14.38	15.25	16.88	18.38	24.13	28.00	32.75	36.88
C	9.00	11.00	13.25	15.56	17.94	20.31	22.56	24.69	27.09	31.56	39.00	45.88	53.00	59.88
D	8.13	8.50	8.63	9.25	9.25	11.50	12.00	12.25	12.50	13.25	18.00	22.00	22.00	24.00
E	1.00	1.00	1.13	1.19	1.25	1.31	1.38	1.38	1.50	1.63	1.81	2.00	2.00	2.00
F (number and size of holes)	4--.75	6--.75	6--.75	8--3/4	8--.75	10--.75	12--.75	12--.75	14--.75	16--.75	20--1.00	24--1.00	28--1.25	32--1.25
G	7.50	9.50	11.75	14.00	16.25	18.75	21.00	23.25	25.50	30.00	36.88	43.75	50.63	57.50
J	4.69	4.69	4.69	5.63	5.63	5.63	6.38	6.38	7.56	7.56	8.31	8.31	10.19	10.19
L	2.00	2.00	2.00	2.44	2.44	2.44	2.84	2.84	3.47	3.47	3.94	3.94	5.06	5.06
Q	4.25	4.25	4.25	5.38	5.38	5.38	6.75	6.75	10.00	10.00	15.94	15.94	14.19	14.19
R	8.25	8.25	8.25	10.38	10.38	10.38	11.31	11.31	17.00	17.00	19.88	19.88	26.50	26.50
X	3.13	3.50	3.63	4.25	4.25	4.50	5.00	5.25	5.50	6.38	10.00	14.00	14.00	16.00
Turns to Open	32	32	32	30	30	30	40	40	44	44	136	136	215	215
Actuator (see notes)	MDT-2S	MDT-2S	MDT-2S	MDT-3S	MDT-3S	MDT-3S	MDT-4S	MDT-4S	MDT-5	MDT-5	MDT-5S	MDT-5S	MDT-6S	MDT-6S

+All dimensions are in inches.

MUELLER® LINESEAL XPII™ BUTTERFLY VALVES (CLASS 250B) 6"-36" - FL x M.J. ENDS

Mueller Co. 11.15

Rev. 9-09

Dimensions - for Lineseal XPII Valves - Flange Ends x Mechanical Joint Ends 6"-20" Sizes.

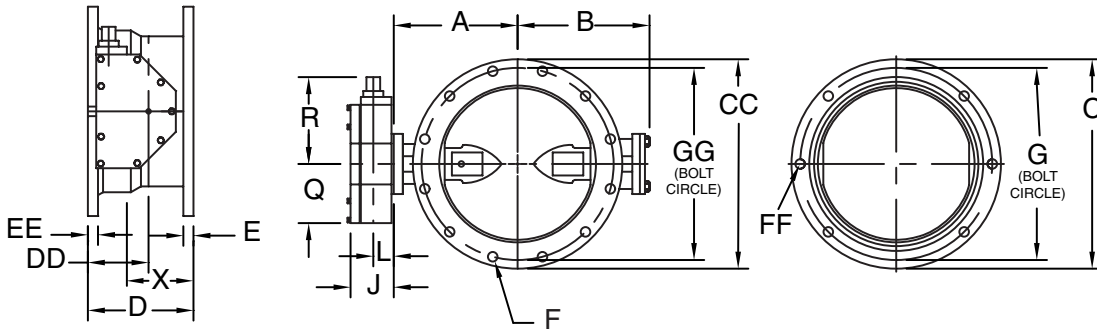

CAUTION
 When using 10" and 12" MJ End Valves on Class 200 C900 PVC Pipe, consult installation instructions supplied with valve for specific installation procedures.

Dimensions - for Lineseal XPII Valves - Flange Ends x Mechanical Joint Ends 24"-36" Sizes.

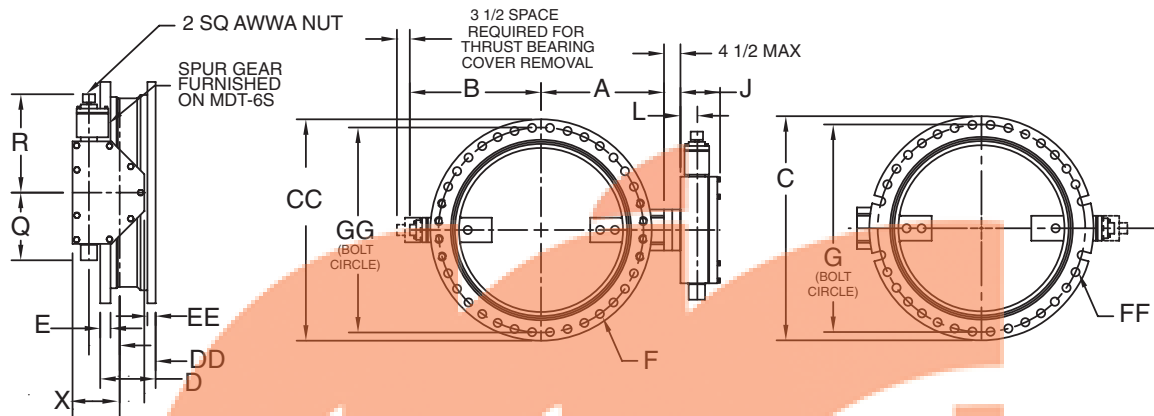

NOTES: These dimensions are correct at time of publication but are not to be construed as certified drawings. Certified drawings are available upon request.

Actuator size subject to change based on actual pipeline conditions.

Dimension+	Nomnal Size										
	6"	8"	10"	12"	14"	16"	18"	20"	24"	30"	36"
A	6.50	7.75	9.00	10.50	11.88	13.50	14.38	16.00	18.63	21.50	25.44
B	5.13	6.50	9.88	11.38	12.75	14.38	15.25	16.88	18.63	24.38	28.25
C	11.00	13.50	16.00	19.00	21.00	23.50	25.00	27.50	32.00	38.75	46.00
CC	11.00	13.25	15.56	17.94	20.31	22.56	24.69	27.09	31.56	39.00	45.88
D	6.75	7.31	8.63	8.63	9.75	10.00	10.13	10.25	10.63	15.00	17.00
DD	4.25	4.31	4.63	4.63	5.75	6.00	6.13	6.25	6.63	9.00	11.00
E	1.06	1.13	1.25	1.25	1.38	1.44	1.56	1.69	1.88	2.13	2.38
EE	1.06	1.13	1.19	1.25	1.31	1.38	1.44	1.50	1.63	1.81	2.00
F (number and size of holes)	8--.75	8--.75	12--.88	12--.88	12--1.00	16--1.00	16--1.13	20--1.13	20--1.25	28--1.25	32--1.50
FF	6--.75	6--.75	8--.75	8--.75	10--.75	12--.75	12--.75	14--.75	16--.75	20--1.00	24--1.00
G	9.50	11.75	14.25	17.00	18.75	21.25	22.75	25.00	29.50	36.00	42.75
GG	9.50	11.75	14.00	16.25	18.75	21.00	23.25	25.50	30.00	36.88	43.75
J	4.69	4.69	5.63	5.63	5.63	6.38	6.38	7.56	7.56	8.31	8.31
L	2.00	2.00	2.44	2.44	2.44	2.84	2.84	3.47	3.47	3.94	3.94
Q	4.25	4.25	5.38	5.38	5.38	6.75	6.75	10.00	10.00	15.94	15.94
R	8.25	8.25	10.38	10.38	10.38	11.31	11.31	17.00	17.00	19.88	19.88
X	4.25	4.81	6.13	6.13	6.25	6.50	6.63	6.75	7.13	11.00	13.00
Turns to Open	32	32	30	30	30	40	40	44	44	136	136
Actuator (see notes)	MDT-2S	MDT-2S	MDT-3S	MDT-3S	MDT-3S	MDT-4S	MDT-4S	MDT-5	MDT-5	MDT-5S	MDT-5S

+All dimensions are in inches.

Rev. 9-09

Line Seal XP & XPII Butterfly Valve Replacement Parts

Catalog Part No.	Description	Material
BF100	Body	Ductile Iron ASTM A-536 (65-45-12)
BF101	Disc	Ductile Iron ASTM A-536 (65-45-12), Edge Type 316 Stainless Steel (3" and 4" Cast Stainless Steel Grade CF8M)
BF102	Shaft	Stainless Steel ASTM A-564 Type 630 Cond. H-1150
BF103	Squeeze Pin	Stainless Steel ASTM A-564 Type 630 Cond. H-1150
BF106	Key	Steel AISI C-1045
BF107	Cover	Cast iron ASTM A-48 Class 40
BF108	Lockwasher	Stainless ASTM A-276 Type 304
BF109	Capscrew	Stainless ASTM A-276 Type 304
BF110	Seat	Buna N (EPDM optional)
BF111	Plug	Cast iron pipe plug
BF112	Bearings	PTFE Lined Stainless Steel (3"-4" Nylon)
BF114	Disc edge	Stainless Steel ASTM A-240 Type 316
BF117	Packing	Buna N Chevron V Type
BF119	Capscrews	Stainless Steel Type 304
BF125	Packing retainer	Nylon
BF126	Bearings	PTFE Lined, Fiberglass backed
BF127	Disc	Ductile Iron ASTM A-536 Grade 65-45-12
BF130	Bottom cover	Cast Iron ASTM A-126 ClassB
BF131	Bottom cover cap	Cast Iron ASTM A-126 ClassB
BF132	Taper pins	Stainless Steel Type 630 ASTM A-564 Cond. H-1150
BF133	Lockwashers	Stainless Steel Type 304
BF134	Hex nuts	Stainless Steel Type 304
BF135	O-rings	Buna N (EPDM Optional)
BF136	Thrust bearing stud	Stainless Steel ASTM A-564 Type 630 Cond. H-1150
BF137	Thrust collar	Bronze ASTM B-505 Alloy C93200
BF138	Groove pin	Alloy Steel
BF139	Bottom cover gasket	Non Asbestos material ASTM F104
BF140	O-ring	Buna N (EPDM optional)
BF150	Top stub shaft	Stainless Steel Type 630 ASTM A-564 Cond. H1150
BF151	Bottom stub shaft	Stainless Steel Type 630 ASTM A-564 Cond. H1150
BF152	Pins	Stainless Steel Type 420
BF153	O-ring	Buna N (EPDM Optional)
BF154	Thrust collar	Bronze ASTM B-505 Alloy C93200
BF155	Plugs	
BF156	Thrust shim	Brass Alloy C26000 Half Hard (HO2)
BF157	Key	Carbon Steel ANSI 1018
BF158	Thrust washer	

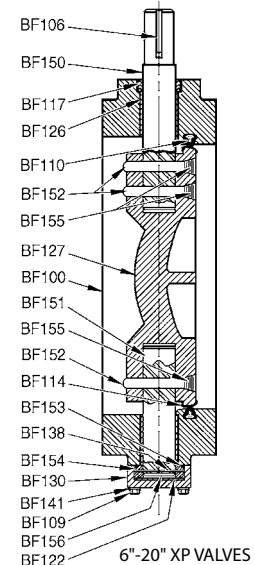
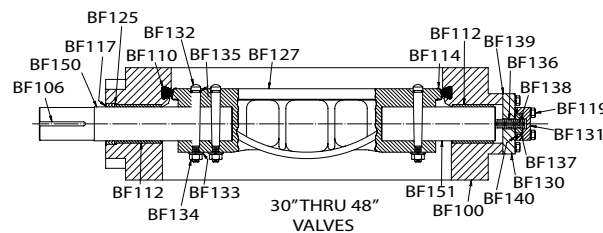
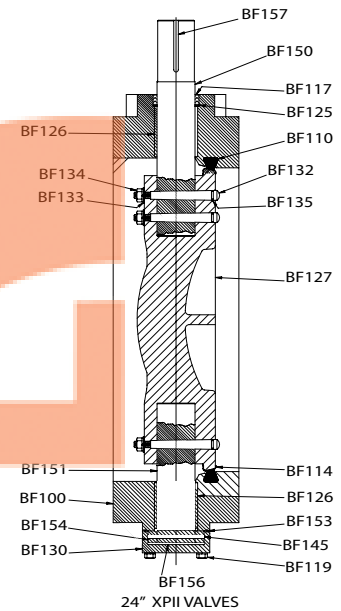
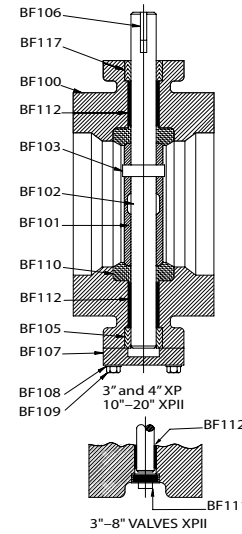

* Contact your Mueller representative for sizes larger than 48".

11.20 **Mueller Co.**

Rev. 9-09



MATERIALES INDUSTRIALES DE GUADALAJARA, S.A. DE C.V.



Av. Artesanos No. 879 Esq. Gobernador
Curiel Col. Artesanos. Tlaquepaque, Jalisco.
C.P. 45590 Tel. (33) 381018
ventas@migsa.com.mx